

# NSK Standard Ball Screws High Speed SS Series

NSK's high speed and low noise ball screws provide high-level performance for drive systems of industrial machines such as those used in manufacturing. A standard stock series assures quick delivery.



## High Speed SS Series (HSS Type); Standard ball screws, high speed and low noise enable further performance improvements to be made.

The HMS and HMD series, originally developed for machine tools, are an addition to NSK's lineup of standard ball screws. They have a wide range of applications, from general machines to high performance machines such as those requiring high speed and precision.

NSK's original recirculation system realized high speed and low noise. An optimum recirculation system has been adopted based on the lead.

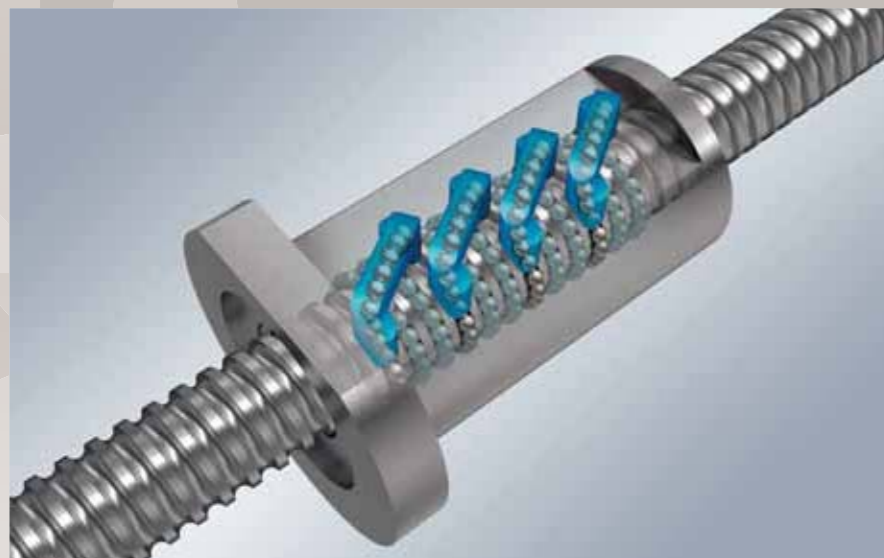

SRC recirculation system is suitable for fine screw leads.

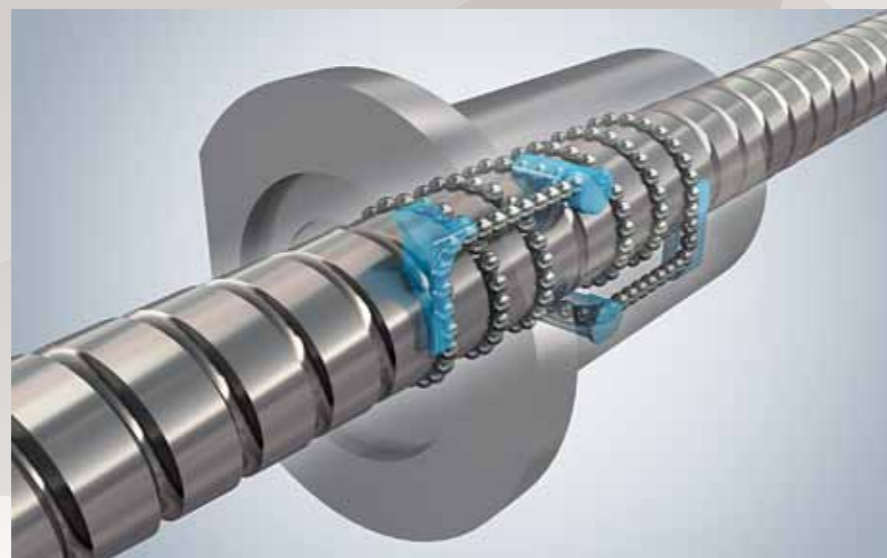

The end deflector and middle deflector recirculation system are suitable for medium leads.

### High speed

Permissible rotational speed is more than double  
d·n limit value: high speed of 160 000

### Low noise and vibrations

Noise level has been reduced by 50%: a reduction of 6 dB  
Vibration has been reduced drastically

### Interchangeability

Installation dimensions are the same as those of a conventional SS series

### Compact

Compact design created using offset preload system

### Convenience

Design flexibility has been improved by blank shaft end.  
New support units are also provided for high speed operation.

**High speed**

The new recirculation system that utilizes NSK's high speed and low noise technology more than doubles the d·n value from 70 000 to 160 000. To extend the range of the lead to 20mm, high speed operation of over 60m/min. is possible.

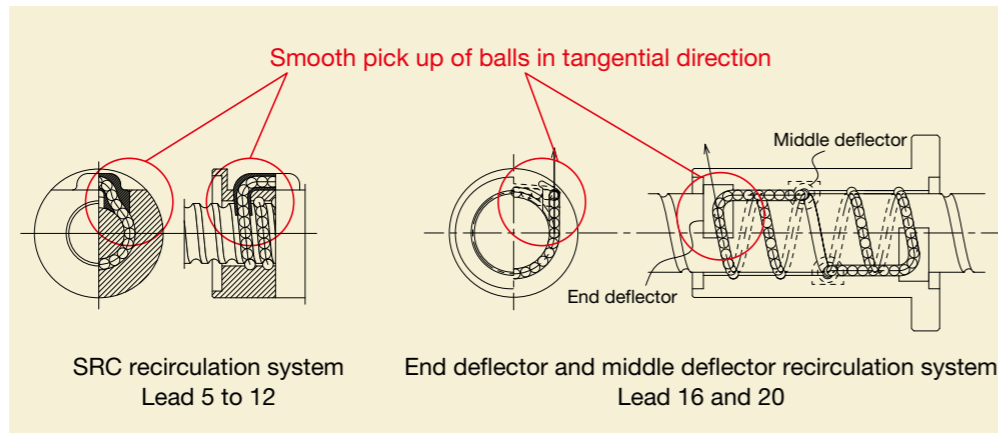

● Allowable feed speed of combinations of shaft diameter and lead.

Shaft diameter [mm] \ Lead [mm]	5	10	12	16	20
32	25m/min	50m/min			
40		40m/min	48m/min	64m/min	80m/min
45		35m/min			
50		32m/min	38m/min		

\*Allowable speed needs to be calculated. See the permissible rotational speed in the dimensions table.

**Low noise and vibrations**

Compared to our conventional products, the average noise level has been reduced by more than 6 dB, reducing the number of colliding balls and recirculation parts thanks to high speed, low noise technology. The vibration level of the nut has also been reduced drastically.

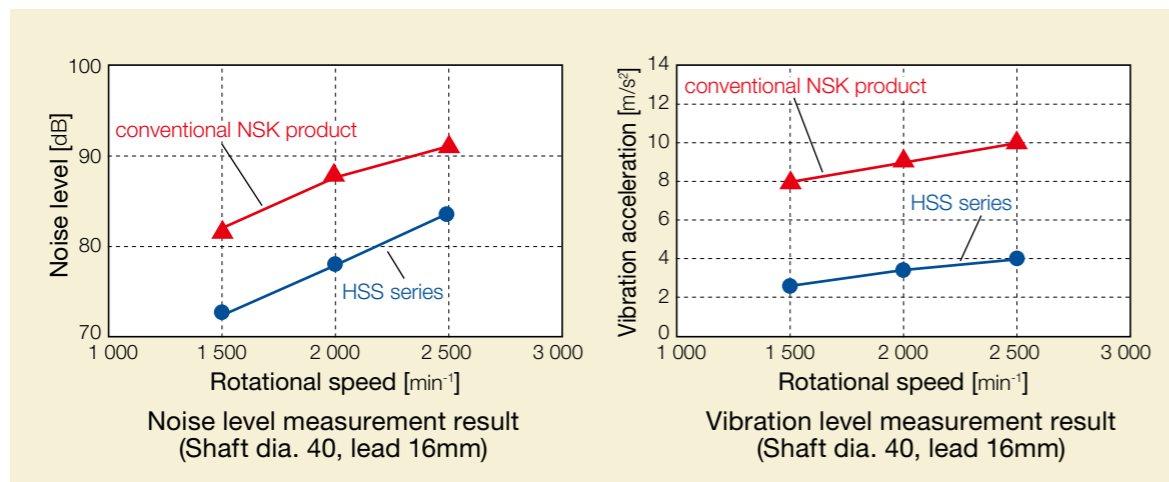

**Interchangeability**

Installation dimensions are the same as those of a conventional SS series

**Compact**

By improving the nut manufacturing technology, highly precise screw manufacturing is possible with the long nut. Achieved high-level stiffness and high load capacity equivalent to that of double nut preload by changing the double nut preload to the offset preload of a single nut, and compact sized nut.

● **Seal**

Adopted thin seals axially and shorten nut length

**Convenience**

● **Optional configurations are possible for ball screw length as well as for the shaft end design**

The blank shaft ends can be customized according to customers' requests. See page 11 in NSK's recommended design when drawing up plans for a shaft end. The support units are available on pages 12-14 in the case of NSK's recommended design.

● **New support unit: For high speeds and heavy loads**

The support unit is applied for the thrust angular contact ball bearing, TAC series, with high precision and rigidity. NSK design is available attached to the support unit, which easily constitutes a system.

● **Oil supply**

2 oil holes, M6×1.0, are provided in the nut flange periphery and the end of the nut flange. A plug is standardly screwed into the periphery of the nut flange.



## Ball screw specification

<b>Accuracy grade</b>	C5 of JIS B 1192 (1997)
<b>Axial play Preload system</b>	Axial play: 0 Offset preload (Z preload)
<b>Thread direction</b>	Right hand
<b>Shaft end</b>	Both shaft ends blank (No case hardening: HRC 40 max.)

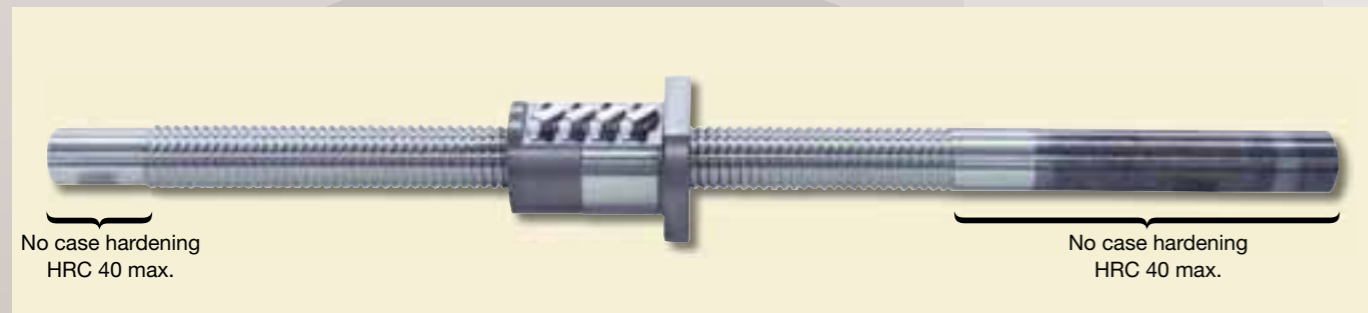

## Reference No.

The reference number is an identification number or symbol used for each model. Specify the reference number when ordering, and thereafter, specify the shape of the end of the shaft indicated by NSK.

Reference No. **HSS** **40** **10** **N1D** **0950**

High speed SS series: HSS

Screw shaft diameter (mm)

Lead (mm)

Screw shaft length  $L_0$  (mm)

NSK control number

## Precautions

### ◆ Design

1. One end of the screw shaft is cut through.
2. If a ball screw of which the left shaft end (opposite the driving side) is the shape  $\bar{I}$ , and if it is supported with the "fixed-fixed" supporting method, you should be aware that the operating life of support bearings may shorten due to thermal expansion of the screw shaft, depending on usage conditions. In this case, you should consider a structure that can accommodate thermal expansion of the screw shaft if necessary. Please consult with NSK for a detailed examination.
3. For general precautions concerning ball screws, please check NSK Catalog No.E3162 "Precision Machine Components".

### ◆ Usage

1. Instructions for shaft end processing  
The high speed SS series has a straight cut shaft end. Therefore, during actual use, the end of the shaft must be machined according to the customer's specifications. NSK recommends designated suppliers that offer quality assurances and precision guarantees. If any other supplier carries out processing, NSK will not provide a precision guarantee.
2. Service temperature environment of 60°C or less (at the nut outer temperature)
3. Only a rust preventive agent is applied at the time of delivery. Please apply lubricant, oil or grease before using.
4. The seals are installed on the end of the nut with the ball screw shaft. However, the ball screws should be provided with a dust cover to prevent debris such as dust and metal powder from entering.
5. If the nut accidentally comes off the screw shaft, please contact NSK.

**Dimension:** Lead 5, 10, and 12 Shaft screw dia.32, 40, 45 and 50

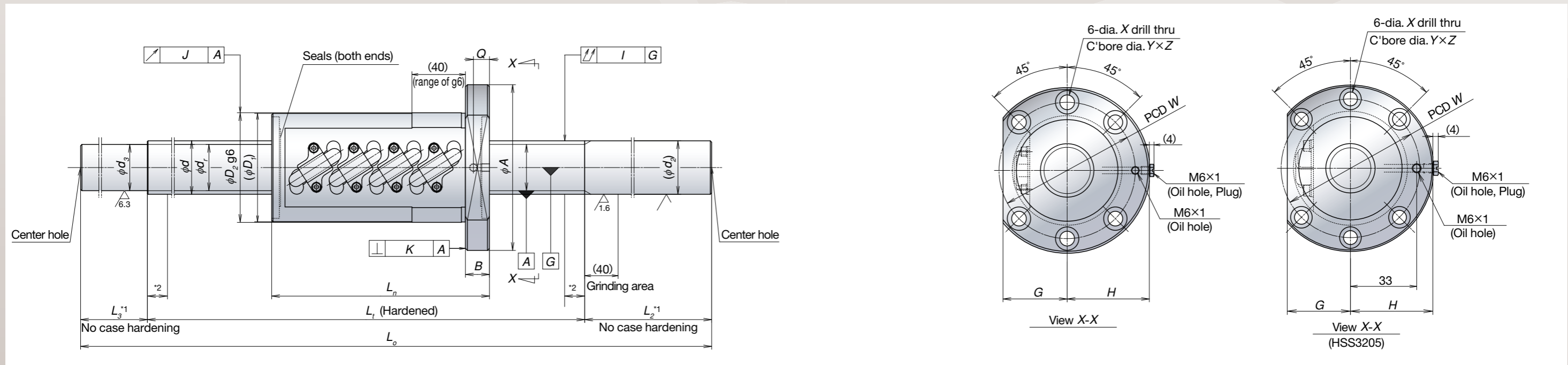

Unit: mm

Reference No.	Screw shaft dia. d	Lead l	Root dia. d <sub>r</sub>	Effective balls turns x Circuits	Basic load rating [N]		Preload [N]	Dynamic friction torque, median [N-cm]	Nut rigidity [N/μm]	Ball nut dimensions								Screw shaft dimension					Lead accuracy			Run-out			Mass [kg]	Permissible rotational speed [min <sup>-1</sup> ]		Internal spatial volume of nut [cm <sup>3</sup> ]				
					Dynamic Ca	Static Coa				Diameter			Flange		Overall length	Bolt hole			Oil hole	Threaded length	Shaft end, right		Shaft end, left		Overall length	Travel compensation T	Deviation e <sub>p</sub>	Variation V <sub>o</sub>		Shaft straightness I	Nut O.D. eccentricity J		Flange perpendicularity K	Installation		
										D <sub>1</sub>	D <sub>2</sub>	A	G	H		B	L <sub>n</sub>	W			X	Y	Z	Q										L <sub>1</sub>	d <sub>2</sub>	L <sub>2</sub>
HSS3205N1D0650	32	5	29.2	2.5x2	18 500	56 100	920	17.0	840	57	58	85	32	42	13	89	71	6.6	11	6.5	8	400	32	200	29.2	50	650	-0.010	0.025	0.020	0.055	0.019	0.013	5.2	5 000	5 000
600																						250		100		950	-0.014	0.030	0.023	0.065	7.0			5 000	5 000	
900																						250		100		1 250	-0.022	0.040	0.027	0.080	8.7			5 000	5 000	
1 150																						300		100		1 550	-0.028	0.046	0.030	0.100	10.5			3 500	4 700	
1 450																						300		100		1 850	-0.035	0.054	0.035	0.130	12.2			2 200	2 900	
HSS3210N1D0850	32	10	26.4	2.5x2	46 300	108 000	2 310	59.5	920	73	74	108	41	53.5	15	160	90	9	14	8.5	10	500	32	250	26.4	100	850	-0.012	0.027	0.020	0.065	0.019	0.013	8.9	5 000	5 000
700																						250		100		1 050	-0.017	0.035	0.025	0.080	10.0			5 000	5 000	
1 050																						300		100		1 450	-0.025	0.046	0.030	0.100	12.2			4 100	5 000	
1 450																						300		100		1 850	-0.035	0.054	0.035	0.130	14.3			2 100	2 800	
1 850																						300		100		2 250	-0.045	0.065	0.040	0.170	16.5			1 200	1 700	
HSS4010N1D0950	40	10	34.4	2.5x2	52 000	137 000	2 600	74.5	1 090	81	82	124	47	61.5	18	163	102	11	17.5	11	12	600	40	250	34.4	100	950	-0.014	0.030	0.023	0.050	0.025	0.015	13.5	4 000	4 000
1 050																						300		100		1 450	-0.025	0.046	0.030	0.070	17.9			4 000	4 000	
1 600																						350		150		2 100	-0.039	0.054	0.035	0.110	23.5			2 200	3 000	
2 400																						350		150		2 900	-0.058	0.077	0.046	0.140	30.5			900	1 300	
1 050																						300		100		1 450	-0.025	0.046	0.030	0.070	19.1			4 000	4 000	
HSS4012N1D2100	40	12	34.1	2.5x2	61 000	155 000	3 050	96.0	1 110	85	86	128	48	63.5	18	187	106	11	17.5	11	12	1 600	40	350	34.1	150	2 100	-0.039	0.054	0.035	0.110	0.025	0.015	24.8	2 200	3 000
2 400																						350		150		2 900	-0.058	0.077	0.046	0.140	31.8			900	1 300	
1 050																						300		100		1 450	-0.025	0.046	0.030	0.070	22.0			3 500	3 500	
1 600																						350		150		2 100	-0.039	0.054	0.035	0.110	29.2			2 500	3 400	
2 400																						350		150		2 900	-0.058	0.077	0.046	0.140	38.2			1 100	1 500	
HSS4510N1D1450	45	10	39.4	2.5x2	54 200	155 000	2 710	82.0	1 210	87	88	132	50	65.5	18	163	110	11	17.5	11	12	1 050	45	300	39.4	100	1 450	-0.025	0.046	0.030	0.070	0.025	0.015	26.3	3 200	3 200
1 600																						350		150		2 100	-0.039	0.054	0.035	0.110	29.2			2 500	3 400	
2 400																						350		150		2 900	-0.058	0.077	0.046	0.140	38.2			1 100	1 500	
1 050																						300		100		1 450	-0.025	0.046	0.030	0.070	26.3			3 200	3 200	
1 450																						300		100		1 850	-0.035	0.054	0.035	0.090	31.9			3 200	3 200	
HSS5010N1D1850	50	10	44.4	2.5x2	57 700	175 000	2 880	92.0	1 320	92	93	135	51	67	18	163	113	11	17.5	11	12	1 850	50	350	44.4	150	2 350	-0.045	0.065	0.040	0.110	0.025	0.015	38.8	2 100	2 900
2 400																						350		150		2 900	-0.058	0.077	0.046	0.140	46.5			1 200	1 700	
1 050																						300		100		1 450	-0.025	0.046	0.030	0.070	28.5			3 200	3 200	
1 600																						350		150		2 100	-0.039	0.054	0.035	0.110	37.3			2 800	3 200	
2 400																						350		150		2 900	-0.058	0.077	0.046	0.140	48.2			1 200	1 600	
HSS5012N1D2100	50	12	43.2	2.5x2	77 600	214 000	3 880	136.5	1 360	99	100	146	55	72.5	22	193	122	14	20	13	12	1 600	50	350	43.2	150	2 100	-0.039	0.054	0.035	0.110	0.025	0.015	37.3	2 800	3 200
2 400																						350		150		2 900	-0.058	0.077	0.046	0.140	48.2			1 200	1 600	

Note: ● NSK support units are recommended. Refer to Page 12 to 14 for details.  
 ● Only a rust preventive agent is applied at the time of delivery. Please apply lubricant, oil or grease before use.  
 ● Nut rigidity: Values in the table are theoretical values obtained from the elastic deformation between ball grooves with preload and balls.

● Permissible rotational speed: Calculated values obtained from the critical speed between the threaded length and NSK's recommended shaft end design.  
 ● \*1: No case hardening: HRC 40 max.  
 ● \*2: Imperfect hardened areas for one lead exists on both ends of a screw. Exercise care when stroke setting

**Dimension:** Lead16, 20 Shaft screw dia.40

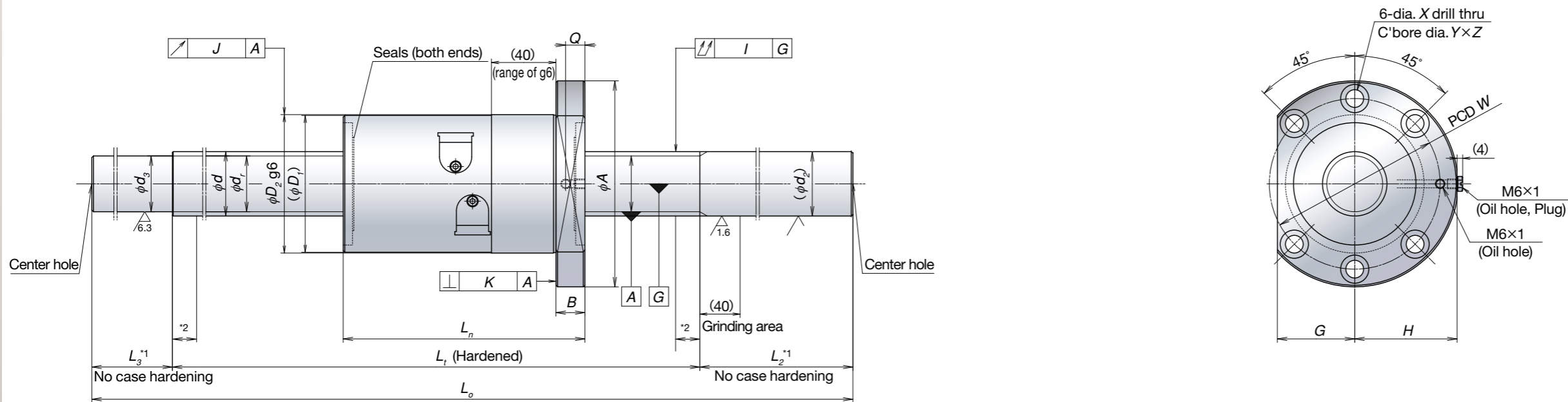

Unit: mm

Reference No.	Screw shaft dia. $d$	Lead $\ell$	Root dia. $d_r$	Effective balls turns $\times$ Circuits	Basic load rating [N]		Preload [N]	Dynamic friction torque, median [N-cm]	Nut rigidity [N/ $\mu$ m]	Ball nut dimensions							Screw shaft dimension					Lead accuracy			Run-out			Mass [kg]	Permissible rotational speed [min <sup>-1</sup> ]		Internal spatial volume of nut [cm <sup>3</sup> ]						
					Dynamic $C_a$	Static $C_oa$				Diameter		Flange			Overall length	Bolt hole				Oil hole	Threaded length	Shaft end, right		Shaft end, left		Overall length	Travel compensation $T$		Deviation $e_p$	Variation $V_v$		Shaft straightness $I$	Nut O.D. eccentricity $J$	Flange perpendicularity $K$	Installation		
										$D_1$	$D_2$	$A$	$G$	$H$		$B$	$L_n$	$W$	$X$			$Y$	$Z$	$Q$	$L_t$										$d_2$	$L_2$	$d_3$
HSS4016N1D1450	40	16	34.1	3.7x1	57 100	130 000	2 850	104.0	970	85	86	128	48	63.5	18	160	106	11	17.5	11	11	1 050	40	300	34.1	100	1 450	-0.025	0.046	0.030	0.070	0.025	0.015	19.2	4 000	4 000	
1 600																						350		150		2 100	-0.039	0.054	0.035	0.110	25.0			2 200	3 000		
2 400																						350		150		2 900	-0.058	0.077	0.046	0.140	32.2			900	1 300		
HSS4016N1D2900		40	16	34.1	3.7x1	57 100	130 000	2 850	104.0	970	85	86	128	48	63.5	18	160	106	11	17.5	11	11	1 050	40	300	34.1	100	1 450	-0.025	0.046	0.030	0.070	0.025	0.015	20.3	4 000	4 000
1 600																							350		150		2 100	-0.039	0.054	0.035	0.110	26.2			2 200	3 000	
2 400																							350		150		2 900	-0.058	0.077	0.046	0.140	33.5			900	1 300	
HSS4020N1D1450	40		20	34.1	3.7x1	57 100	130 000	2 850	116.5	960	85	86	128	48	63.5	18	192	106	11	17.5	11	11	1 050	40	300	34.1	100	1 450	-0.025	0.046	0.030	0.070	0.025	0.015	20.3	4 000	4 000
1 600																							350		150		2 100	-0.039	0.054	0.035	0.110	26.2			2 200	3 000	
2 400																							350		150		2 900	-0.058	0.077	0.046	0.140	33.5			900	1 300	

- Note:
- NSK support units are recommended. Refer to Page 12 to 14 for details.
  - Only a rust preventive agent is applied at the time of delivery. Please apply lubricant, oil or grease before use.
  - Nut rigidity: Values in the table are theoretical values obtained from the elastic deformation between ball grooves with preload and balls.

- Permissible rotational speed: Calculated values obtained from the critical speed between the threaded length and NSK's recommended shaft end design.
- \*1: No case hardening: HRC 40 max.
- \*2: Imperfect hardened areas for one lead exists on both ends of a screw. Exercise care when stroke setting

**Dimension: Recommendation for shaft end design**

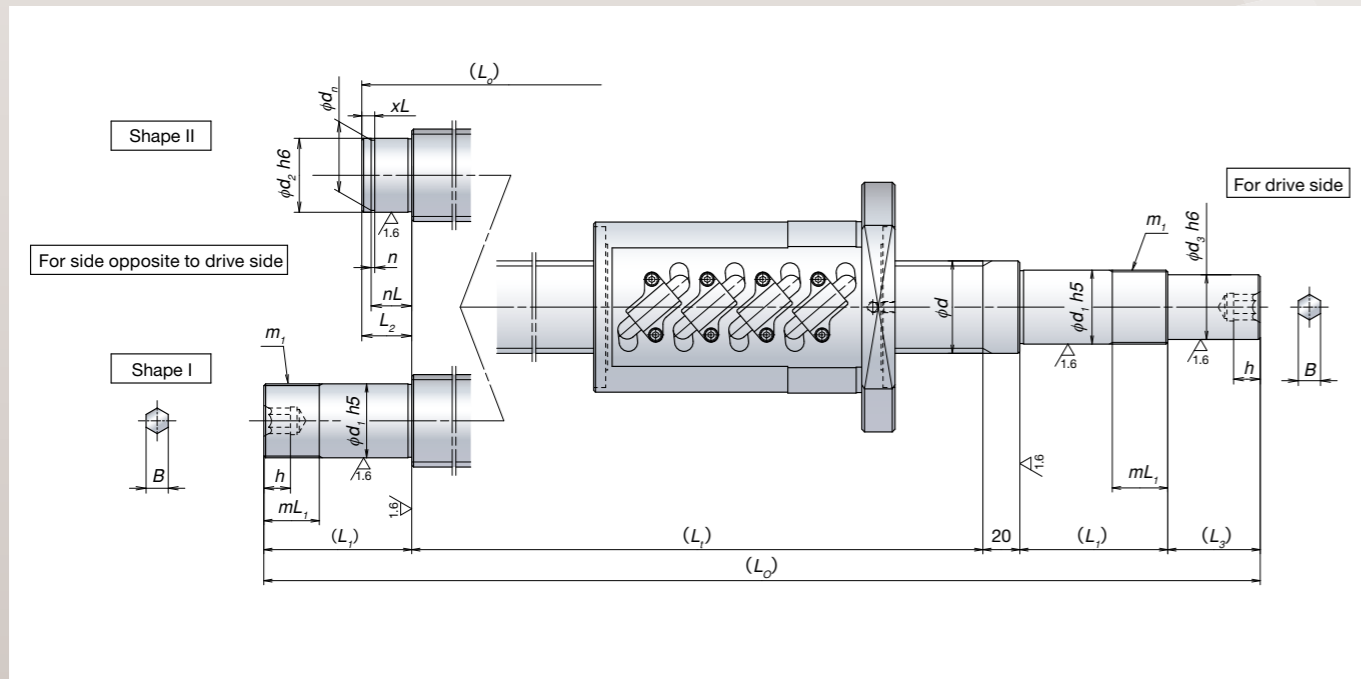

For drive side: Recommendation for shaft end design

Unit: mm

Screw shaft diameter	Bearing installation		Thread screw		Support unit	Parts installation		Shaft length			
	Diameter	Length	Screw size	Length		Diameter	Length	Screw length	Shaft overall length	Shaft end hexagon hole	
<i>d</i>	<i>d<sub>1</sub></i>	<i>L<sub>1</sub></i>	<i>m<sub>1</sub></i>	<i>mL<sub>1</sub></i>		<i>d<sub>3</sub></i>	<i>L<sub>3</sub></i>	<i>L<sub>t</sub></i>	<i>L<sub>o</sub></i>	<i>B</i>	<i>h</i>
32	25	89	M25×1.5	26	WBK25DF-31H WBK25DFD-31H	20	51	max 1 850	max 2 250	8 <sup>+0.2</sup> <sub>0</sub>	10
		104									
40	30	89	M30×1.5	26	WBK30DF-31H WBK30DFD-31H	25	61	max 2 400	max 2 900	10 <sup>+0.2</sup> <sub>0</sub>	12
		104									
45	35	92	M35×1.5	30	WBK35DF-31H WBK35DFD-31H WBK35DFF-31H	30	63	max 2 400	max 2 900	12 <sup>+0.3</sup> <sub>0</sub>	14
		107									
		122									
50	40	92	M40×1.5	30	WBK40DF-31H WBK40DFD-31H WBK40DFF-31H	35	78	max 2 400	max 2 900	14 <sup>+0.3</sup> <sub>0</sub>	18
		107									
		122									

For side opposite to drive side: Recommendation for shaft end design

Unit: mm

Screw shaft diameter	Shape	Bearing installation		Thread screw		Snap ring ditch			Support unit (Bearing model)
		Diameter	Length	Screw size	Length	Width	Ditch diameter	Ditch location	
<i>d</i>		<i>d<sub>2</sub></i>	<i>L<sub>2</sub></i>	<i>m<sub>2</sub></i>	<i>mL<sub>2</sub></i>	<i>n</i>	<i>d<sub>n</sub></i>	<i>nL (xL)</i>	
32	I			*		-	-	-	*
	II	25	20	-	-	1.35 <sup>+0.14</sup> <sub>0</sub>	23.9 <sup>-0.21</sup> <sub>0</sub>	16.35 (5)	(6205)
40	I			*		-	-	-	*
	II	30	22	-	-	1.75 <sup>+0.14</sup> <sub>0</sub>	28.6 <sup>-0.21</sup> <sub>0</sub>	17.75 (6)	(6206)
45	I			*		-	-	-	*
	II	35	23	-	-	1.75 <sup>+0.14</sup> <sub>0</sub>	33 <sup>-0.25</sup> <sub>0</sub>	18.75 (6)	(6207)
50	I			*		-	-	-	*
	II	40	25	-	-	1.95 <sup>+0.14</sup> <sub>0</sub>	38 <sup>-0.25</sup> <sub>0</sub>	19.95 (7)	(6208)

Note: ● The dimensions of the drawing can be flexibly set within limits.  
 ● The support unit is available with a recommended design.  
 ● \*: The same as that of the drive side.

**New support unit (For high speed and heavy load)**



Heat generation has been reduced via adoption of a low preload type bearing. Along with speedup of the ball screw, permissible rotational speed have been improved.

The new support units are assembled with the thrust angular contact ball bearings, TAC series, which are a high precision, high rigidity, high speed type with the most suitable function and structure. The bearing combination comes in three types as shown in the figure below

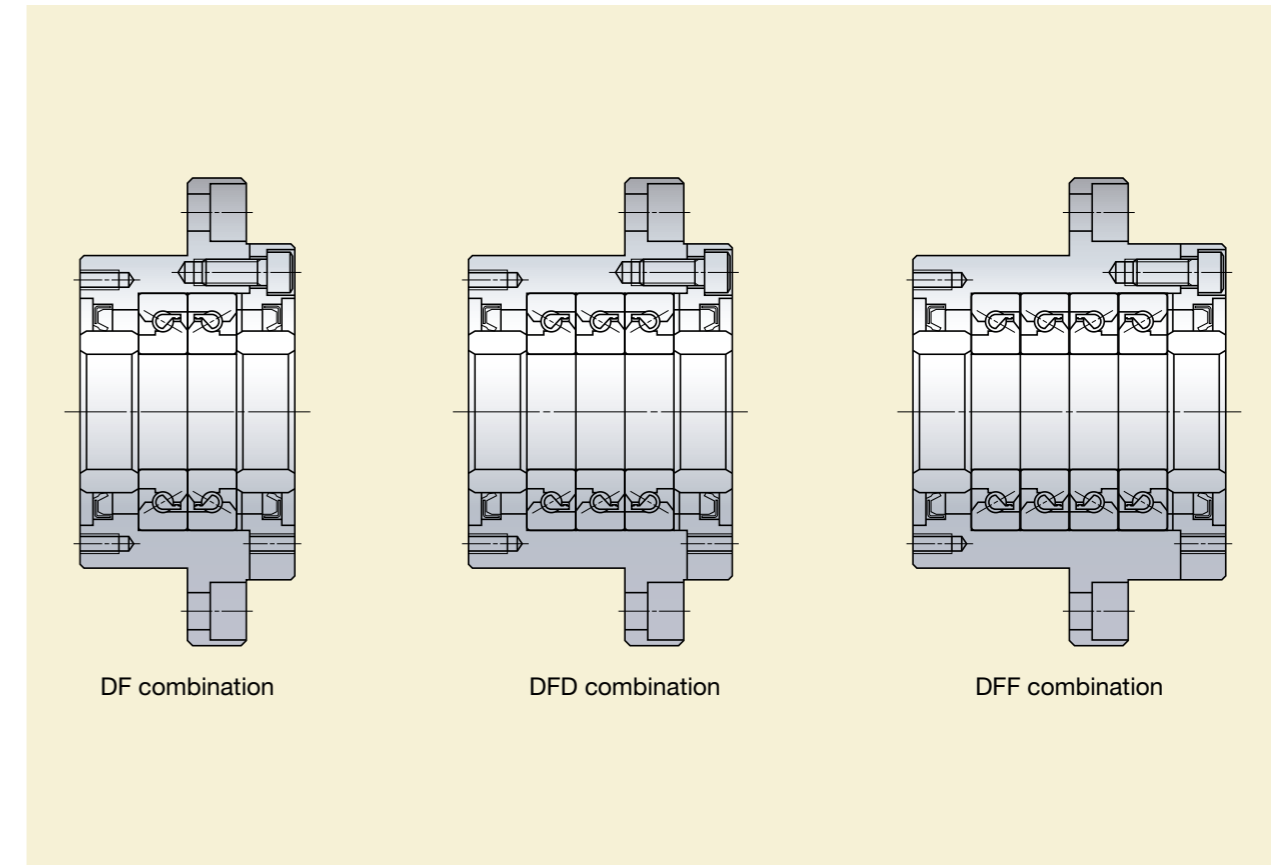

**Support unit reference No.**

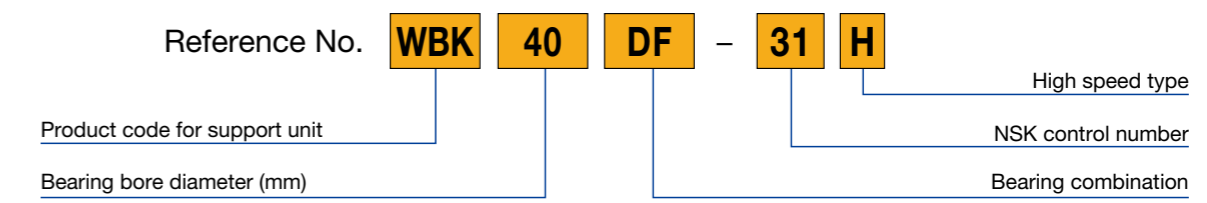



**Dimension: Support unit**

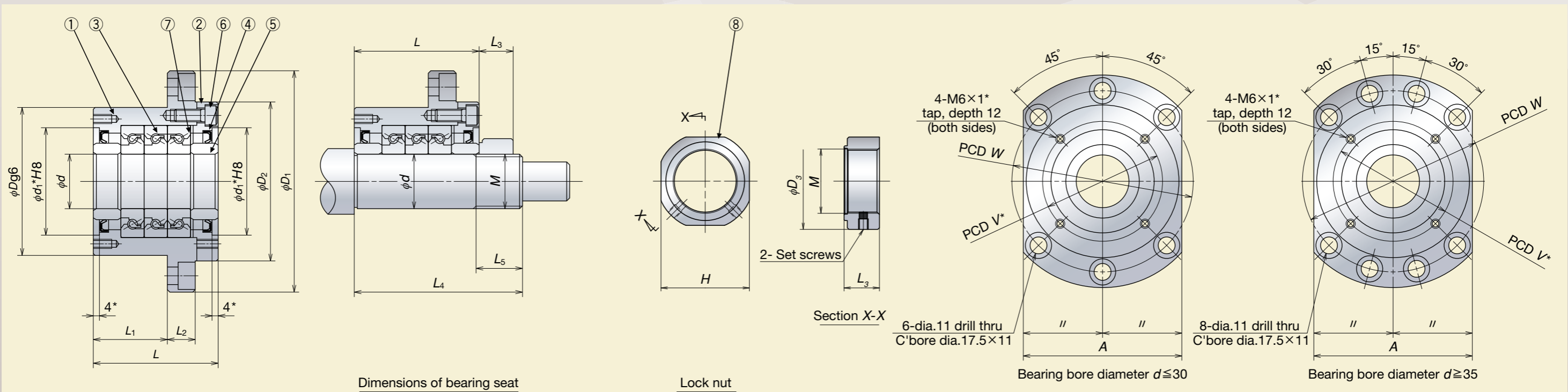

Unit: mm

Reference No.	Support unit											Basic dynamic load rating [N]	Permissible axial load [N]	Preload [N]	Axial rigidity [N/μm]	Maximum starting torque [N·cm]	Lock nut				Bearing seat for unit			Permissible rotational speed [min <sup>-1</sup> ]	Mass [kg]	
	d	D	D <sub>1</sub>	D <sub>2</sub>	L	L <sub>1</sub>	L <sub>2</sub>	A	W	d <sub>1</sub> *	V*						Length				Installation torque [N·cm]	d	L <sub>4</sub>			L <sub>5</sub>
																	M	H	D <sub>3</sub>	L <sub>3</sub>						
WBK25DF-31H	25	85	130	90	66	33	18	100	110	57	70	29 900	40 500	2 280	850	21	M25×1.5	41	45	20	8 500	25	89	26	5 200	3.1
WBK25DFD-31H					81	48						48 500	81 500	3 100	1 250	28							104			3.4
WBK30DF-31H	30	85	130	90	66	33	18	100	110	57	70	30 500	43 000	2 400	890	23	M30×1.5	46	50	20	10 100	30	89	26	4 900	3.0
WBK30DFD-31H					81	48						50 000	86 000	3 260	1 310	30							104			3.3
WBK35DF-31H	35	95	142	102	66	33	18	106	121	69	80	32 500	50 000	2 750	1 030	27	M35×1.5	50	55	22	13 800	35	92	30	4 100	3.4
WBK35DFD-31H					81	48						53 000	100 000	3 740	1 500	34							107			4.3
WBK35DFF-31H					96	48						53 000	100 000	5 490	2 060	43							122			5.0
WBK40DF-31H	40	95	142	102	66	33	18	106	121	69	80	33 500	52 000	2 860	1 080	28	M40×1.5	55	60	22	15 500	40	92	30	4 100	3.6
WBK40DFD-31H					81	48						54 000	104 000	3 900	1 590	36							107			4.2
WBK40DFF-31H					96	48						54 000	104 000	5 730	2 150	46							122			4.7

- Note:
- Rigidity: Values in the table are theoretical and obtained from the elastic deformation between ball groove and balls.
  - Starting torque indicates torque due to the preload of the bearing. It does not include seal torque.
  - h5 class of the fits tolerance is recommended.
  - Pilot diameter and tapped screws marked with "\*", are used for seal unit installation for NSK standard hollow shaft ball screws. They can also be used for the dust cover and damper installation.
  - Grease is packed into bearings. It is not necessary to apply grease before use.
  - Installation torque of a set screw 490[N·cm] (Reference value)
  - The locknut has been designed to stay fastened, but it may come loose if a machine has strong vibrations. Apply construction adhesive as necessary.
  - Allowable axial load is 0.7 times of the permissible axial load in the dimension table.

Parts list

Parts No.	Part Name	Quantity
①	Housing	1
②	Retaining Cover	1
③	High accuracy thrust angular contact ball bearing	One set
④	Dust seal	2
⑤	Collar	2
⑥	Preload bolt	6 or 8
⑦	Shim	One set
⑧	Lock nut	1

- NSK support units are precisely preloaded and adjusted. Do not disassemble components ①, ②, ③, ④, ⑥ or ⑦.
- Lock nut ⑧ has been exclusively prepared for ball screws. The end surface of the nut is positioned precisely perpendicular to the V thread. Secure the lock nut using a set screw.



## Worldwide Sales Offices

P: Phone ☆: Head Office

### NSK LTD. HEADQUARTERS, TOKYO JAPAN

INDUSTRIAL MACHINERY BUSINESS DIVISION-HEADQUARTERS P: +81-3-3779-7227  
 AUTOMOTIVE BUSINESS DIVISION-HEADQUARTERS P: +81-3-3779-7189

#### Africa

##### South Africa:

#### NSK SOUTH AFRICA (PTY) LTD.

JOHANNESBURG P: +27-11-458-3600

#### Aisia and Oceania

##### Australia:

#### NSK AUSTRALIA PTY. LTD.

MELBOURNE ☆ P: +61-3-9765-4400  
 SYDNEY P: +61-2-8843-8100  
 BRISBANE P: +61-7-3347-2600  
 PERTH P: +61-8-9256-5000

##### New Zealand:

#### NSK NEW ZEALAND LTD.

AUCKLAND P: +64-9-276-4992

##### China:

#### NSK HONG KONG LTD.

HONG KONG ☆ P: +852-2739-9933  
 SHENZHEN P: +86-755-25904886

#### NSK (SHANGHAI) TRADING CO., LTD.

JIANGSU P: +86-512-5796-3000

#### NSK (CHINA) INVESTMENT CO., LTD.

JIANGSU ☆ P: +86-512-5796-3000  
 BEIJING P: +86-10-6590-8161  
 TIAN JIN P: +86-22-8319-5030  
 CHANGCHUN P: +86-431-8898-8682  
 SHENYANG P: +86-24-2334-2868  
 DALIAN P: +86-411-8800-8168  
 NANJING P: +86-25-8472-6671  
 FUZHOU P: +86-591-8380-1030  
 WUHAN P: +86-27-8556-9630  
 QINGDAO P: +86-532-5568-3877  
 GUANGZHOU P: +86-20-3817-7800  
 CHANGSHA P: +86-731-8571-3100  
 LUOYANG P: +86-379-6069-6188  
 XI'AN P: +86-29-8765-1896  
 CHONGQING P: +86-23-6806-5310  
 CHENGDU P: +86-28-8528-3680

#### NSK CHINA SALES CO., LTD.

JIANGSU P: +86-512-5796-3000

##### India:

#### NSK INDIA SALES CO.PVT.LTD.

CHENNAI ☆ P: +91-44-2847-9600  
 GURGAON P: +91-124-4104-530  
 MUMBAI P: +91-22-2838-7787

##### Indonesia:

#### PT. NSK INDONESIA

JAKARTA P: +62-21-252-3458

##### Korea:

#### NSK KOREA CO., LTD.

SEOUL P: +82-2-3287-0300

##### Malaysia:

#### NSK BEARINGS (MALAYSIA) SDN.BHD.

SHAH ALAM ☆ P: +60-3-7803-8859  
 PRAI P: +60-4-3902275  
 JOHOR BAHRU P: +60-7-3546290  
 IPOH P: +60-5-2555000

##### Philippines:

#### NSK REPRESENTATIVE OFFICE

MANILA P: +63-2-893-9543

##### Singapore:

#### NSK INTERNATIONAL (SINGAPORE) PTE LTD.

SINGAPORE P: +65-6496-8000

#### NSK SINGAPORE (PRIVATE) LTD.

SINGAPORE P: +65-6496-8000

##### Taiwan:

#### TAIWAN NSK PRECISION CO., LTD.

TAIPEI ☆ P: +886-2-2509-3305  
 TAICHUNG P: +886-4-2311-7978  
 TAINAN P: +886-6-505-5861

#### TAIWAN NSK TECHNOLOGY CO., LTD.

TAIPEI ☆ P: +886-2-2509-3305  
 TAICHUNG P: +886-4-2358-2945  
 TAINAN P: +886-6-505-5861

##### Thailand:

#### NSK BEARINGS (THAILAND) CO., LTD.

BANGKOK P: +66-2320-2555

##### Vietnam:

#### NSK VIETNAM CO., LTD.

HANOI P: +84-4-3955-0159

#### NSK REPRESENTATIVE OFFICE

HO CHI MINH CITY P: +84-8-3822-7907

##### Europe

##### United Kingdom:

#### NSK EUROPE LTD. (EUROPEAN HEADQUARTERS)

MAIDENHEAD P: +44-1628-509-800

#### NSK UK LTD.

NEWARK P: +44-1636-605-123

##### France:

#### NSK FRANCE S.A.S.

PARIS P: +33-1-30-57-39-39

##### Germany:

#### NSK DEUTSCHLAND GMBH

DUSSELDORF ☆ P: +49-2102-4810  
 STUTTGART P: +49-711-79082-0  
 WOLFSBURG P: +49-5361-27647-10

##### Italy:

#### NSK ITALIA S.P.A.

MILANO P: +39-299-5191

##### Netherlands:

#### NSK EUROPEAN DISTRIBUTION CENTRE B.V.

TILBURG P: +31-13-4647647

##### Poland:

#### NSK REPRESENTATIVE OFFICE

WARSAW P: +48-22-645-1525

##### Russia:

#### NSK POLSKA SP. Z O.O.

SAINT-PETERSBURG P: +7-812-332-5071

##### Spain:

#### NSK SPAIN S.A.

BARCELONA P: +34-93-433-5775

##### Turkey:

#### NSK RULMANLARI ORTA DOGU TIC. LTD. STL

ISTANBUL P: +90-216-477-7111

##### UAE:

#### NSK BEARINGS GULF TRADING CO.

DUBAI P: +971-4-804-8200

##### North and South America

##### United States of America:

#### NSK AMERICAS, INC. (AMERICAN HEADQUARTERS)

ANN ARBOR P: +1-734-913-7500

#### NSK CORPORATION

ANN ARBOR P: +1-734-913-7500

#### NSK PRECISION AMERICA, INC.

FRANKLIN ☆ P: +1-317-738-5000

SAN JOSE P: +1-408-944-9400

#### NSK LATIN AMERICA, INC.

MIAMI P: +1-305-477-0605

##### Canada:

#### NSK CANADA INC.

TORONTO ☆ P: +1-905-890-0740

MONTREAL P: +1-514-633-1220

VANCOUVER P: +1-877-994-6675

##### Argentina:

#### NSK ARGENTINA SRL

BUENOS AIRES P: +54-11-4704-5100

##### Brazil:

#### NSK BRASIL LTDA.

SAO PAULO ☆ P: +55-11-3269-4786

BELO HORIZONTE P: +55-31-3274-2591

JOINVILLE P: +55-47-3422-5445

PORTO ALEGRE P: +55-51-3222-1324

RECIFE P: +55-81-3326-3781

##### Peru:

#### NSK PERU S.A.C.

LIMA P: +51-1-652-3372

##### Mexico:

#### NSK RODAMIENTOS MEXICANA, S.A. DE C.V.

MEXICO CITY ☆ P: +52-55-3682-2900

MONTERREY P: +52-81-8000-7300

<As of June 2013>

For the latest information, please refer to the NSK website.

[www.nsk.com](http://www.nsk.com)

NSK Ltd. has a basic policy not to export any products or technology designated as controlled items by export-related laws. When exporting the products in this brochure, the laws of the exporting country must be observed. Specifications are subject to change without notice and without any obligation on the part of the manufacturer. Every care has been taken to ensure the accuracy of the data contained in this brochure, but no liability can be accepted for any loss or damage suffered through errors or omissions. We will gratefully acknowledge any additions or corrections.

For more information about NSK products, please contact: \_\_\_\_\_

